

G500 WATER & WASTE SYSTEM

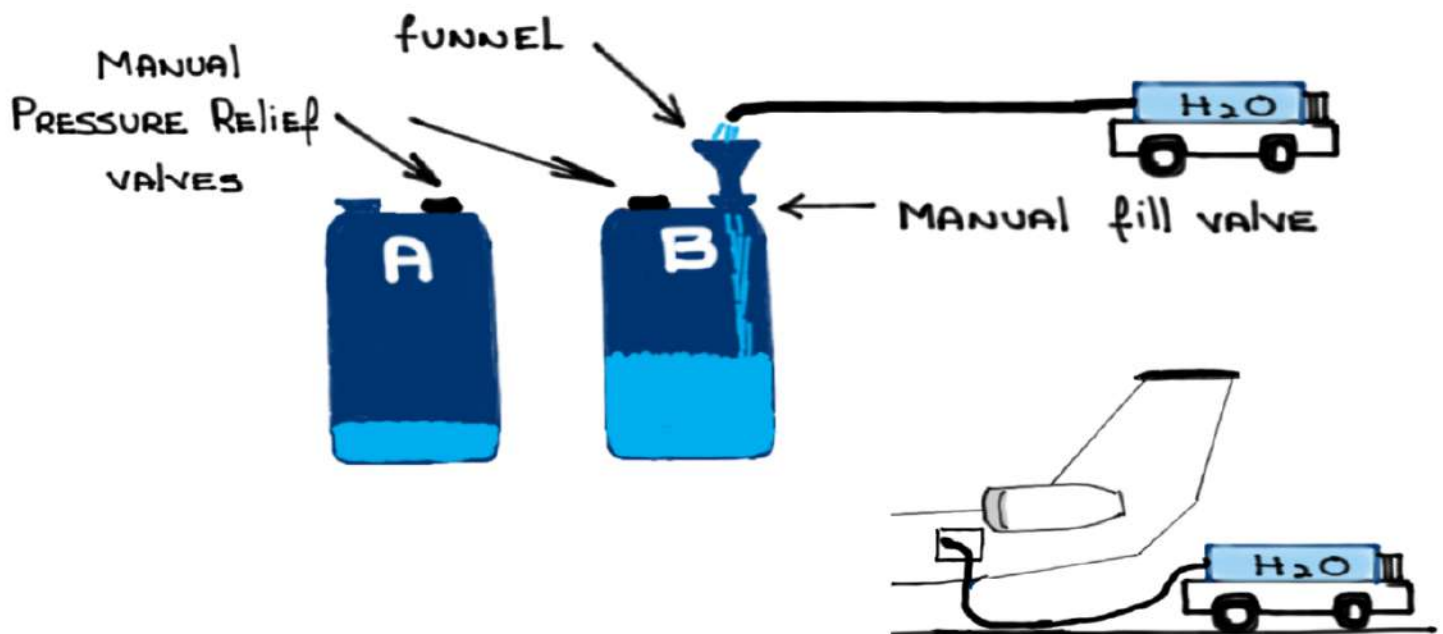

For study purposes only

The POTABLE WATER SYSTEM (PWS) is ABOUT THE STORAGE AND DISTRIBUTION of POTABLE, FILTERED WATER AND ITS USE IN:



- THE PWS IS ACTIVATED VIA THE:



- THE PWS IS OPERATED, MONITORED AND PURGED VIA THE TOUCH SCREEN GULFSTREAM CABIN MANAGEMENT SYSTEM (GCMS) LOCATED IN THE GALLEY. A SEPARATE TOUCH SCREEN CONTROLLER, LOCATED NEAR THE MAIN ENTRANCE DOOR, CAN PERFORM SOME PWS FUNCTIONS

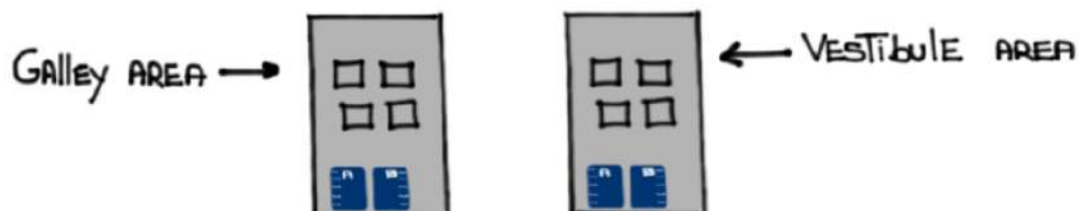

- The PWS has a capacity of Thirty (30) gallons and is comprised of two (2) independent tanks. This design enhances system redundancy

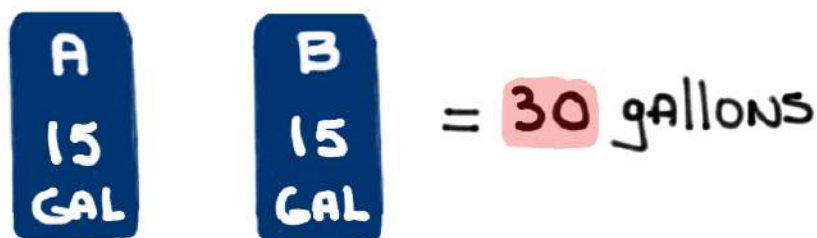

- The PWS tanks are located in the baggage compartment and are serviced through an access panel located on the left side of the aircraft

- AOM

HANDLING AND SERVICES PROCEDURES

- No ELECTRICAL POWER REQUIRED
- GSB POWER NEEDED FOR WATER LEVEL INDICATION
- TANKS ARE SERVICED INDIVIDUALLY
- SEVEN (7) MINUTES TO SERVICE EACH TANK
- BOTH TANKS should BE SERVICED TO THE SAME LEVEL
- PWS IS INHIBITED WHILE THE EXTERNAL SERVICE PANEL DOOR IS OPEN

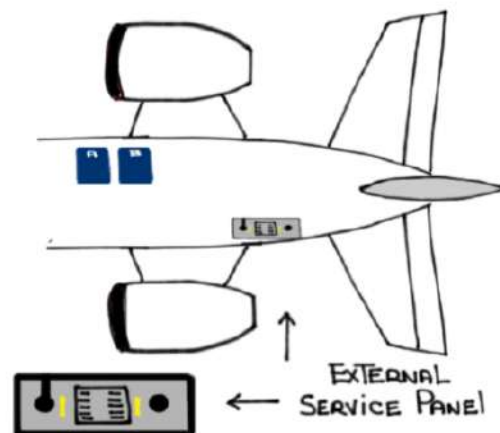

- THE TANKS ARE COMPLETELY FULL WHEN WATER OVERFLOWS FROM THE AFT DRAIN MAST

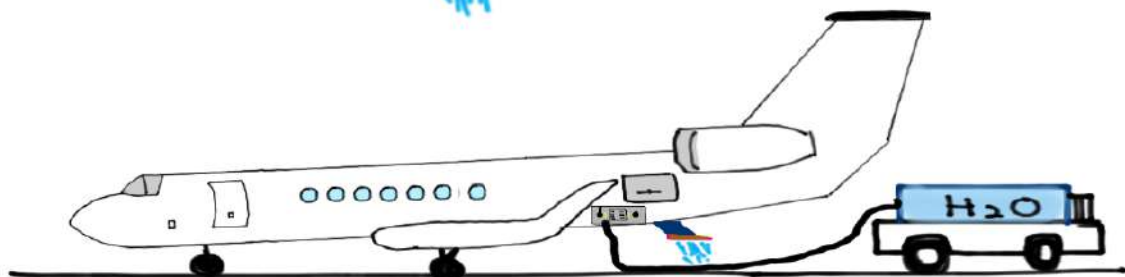
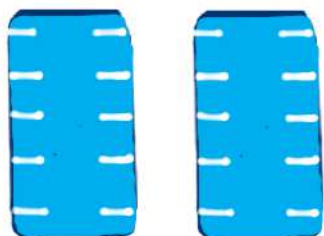

- A MANUAL fill valve is installed on top of EACH TANK TO ALLOW filling of THE TANKS WITH A FUNNEL AND A HOSE PASSED THROUGH THE OPEN baggage door.

PRESSURE WITHIN THE TANK MUST BE bled off BEFORE OPENING THE fill valve

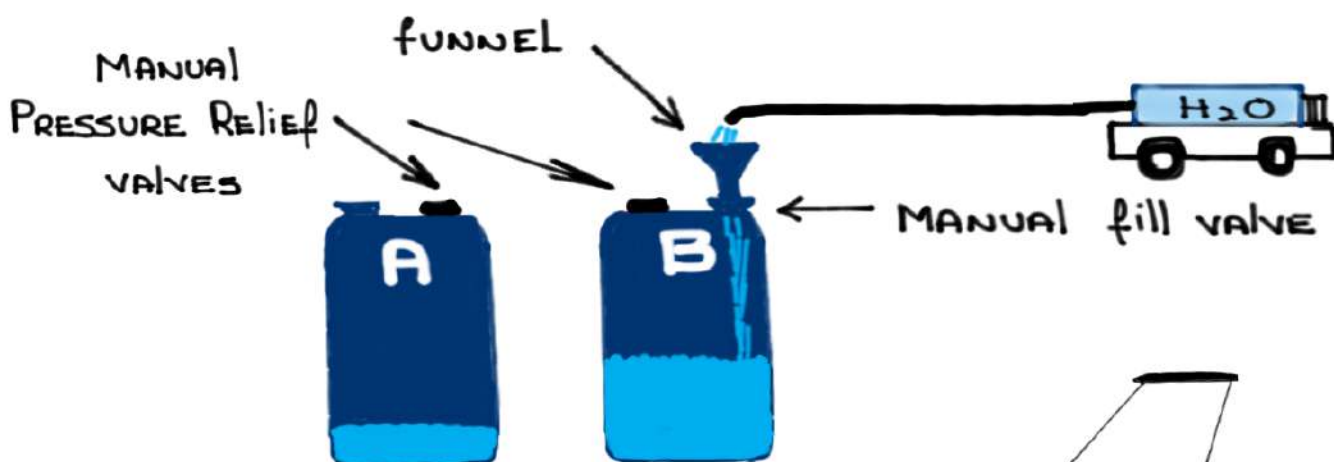

- The PWS TANKS ARE PRESSURIZED by:

- ① Electrically-powered air compressor, OR
- ② Engine bleed air, OR
- ③ APU bleed air

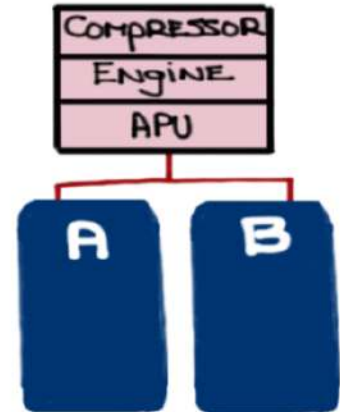

- Upon exiting the tanks the water passes through a filter and ultraviolet light sterilization unit for purification purposes



- There are five (5) sensor probes mounted on the side of each tank. These probes sense the water level in each tank and display in at four (4) locations:

GCMS Touchscreens

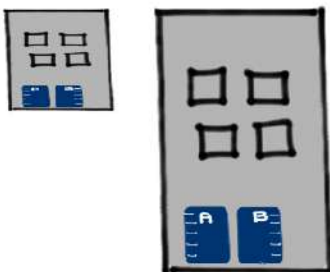

TANK ENCLOSURE



EXTERNAL SERVICE PANEL





- TO PREVENT WATER FROM FLOWING FROM THE FAUCETS UNINTENTIONALLY THERE IS A PRESSURE PAD UNDERNEATH THE LAVATORY FLOORS. WEIGHT ON THE PADS, AS WHEN SOMEBODY IS STANDING IN FRONT OF THE SINK, ALLOWS WATER TO FLOW FROM AN OPEN FAUCET

IF NO WATER IS AVAILABLE AN OVERRIDE LEVER UNDER THE SINK IN THE AFT LAVATORY BYPASSES THE ELECTRICAL INPUT FROM THE PRESSURE PAD. THIS OVERRIDE LEVER IS NOT AVAILABLE IN THE FORWARD LAVATORY

- ELECTRICAL HEATERS, POWERED BY 115 VAC, AS WELL AS INSULATION, ARE USED TO PREVENT WATER FROM FREEZING

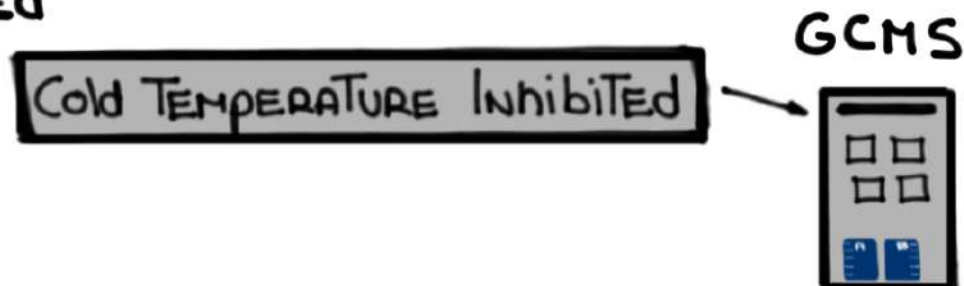
- FOLLOWING AN OVERNIGHT COLD SOAK THE PWS IS PREVENTED FROM ACTIVATING UNTIL THE CABIN TEMPERATURE REACHES 35°F OR A 20 MINUTE WARM-UP TIME HAS ELAPSED



- THE PWS CAN BE PURGED VIA THE  TO KEEP WATER FROM FREEZING IN THE LINES AND CAUSING EXTENSIVE DAMAGE DUE TO LINE RUPTURE AND SUBSEQUENT WATER LEAKS

AOM

HANDLING AND SERVICES PROCEDURES

 DESCRIBE TWO (2) PURGE MODES

- LINE DRAIN COMMAND: REMOVES ALL WATER FROM THE PWS LINES
- SYSTEM PURGE COMMAND: FORCES AIR THROUGH THE WATER FILTER AND LINES AS WELL AS THE TANKS UNTIL ALL REMAINING WATER HAS BEEN PURGED

AIR

- Aft DRAIN MAST
- PURGE aided by:

GCMS



← PURGE MODE

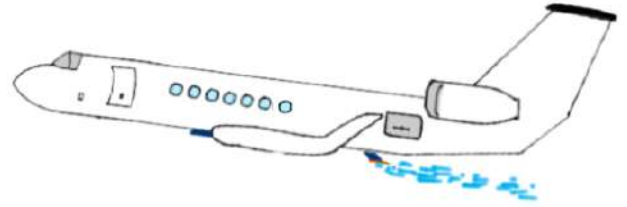

- ① NOSE up ATTITUDE
- ② DIFFERENTIAL PRESSURE (High To Low)

- FIVE (5) MINUTES PER TANK
 - PURGE is COMPLETED ONLY AFTER LANDING SINCE THE FORWARD SUPPLY/DRAIN VALVES (V4A, V4B AND V5) DON'T OPEN UNTIL WOW - **Ground**
-

GROUND

- HEATED PENETRATION PORT
- PURGE aided by NOSE DOWN ATTITUDE
- FIVE (5) MINUTES PER TANK

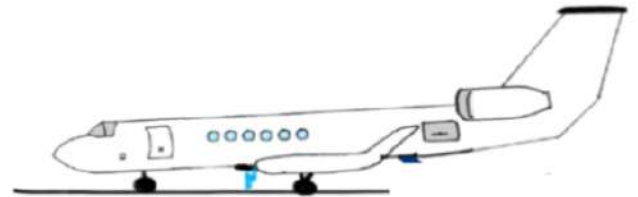

- WATER FROM THE FORWARD AND AFT LAVATORIES' SINKS, AS WELL AS FROM THE GALLEY'S SINK AND ICE STORAGE DRAWERS, IS DRAINED OVERBOARD VIA THE:

- HEATED PENETRATION PORT - GROUND
- AFT DRAIN MAST - Air

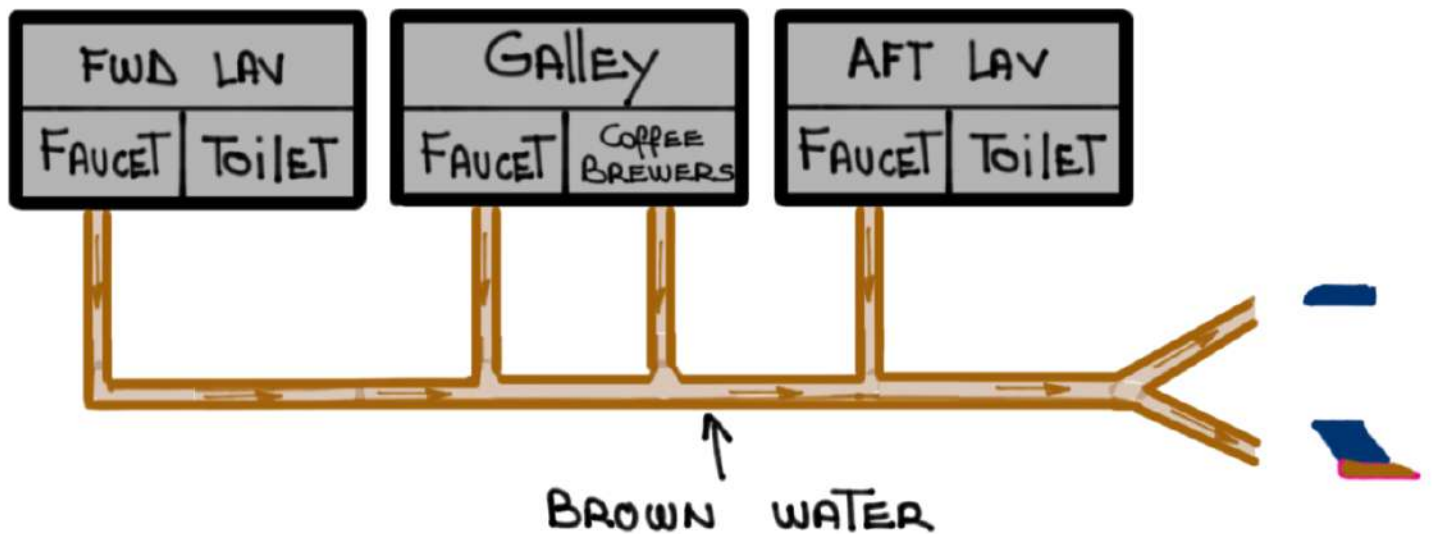
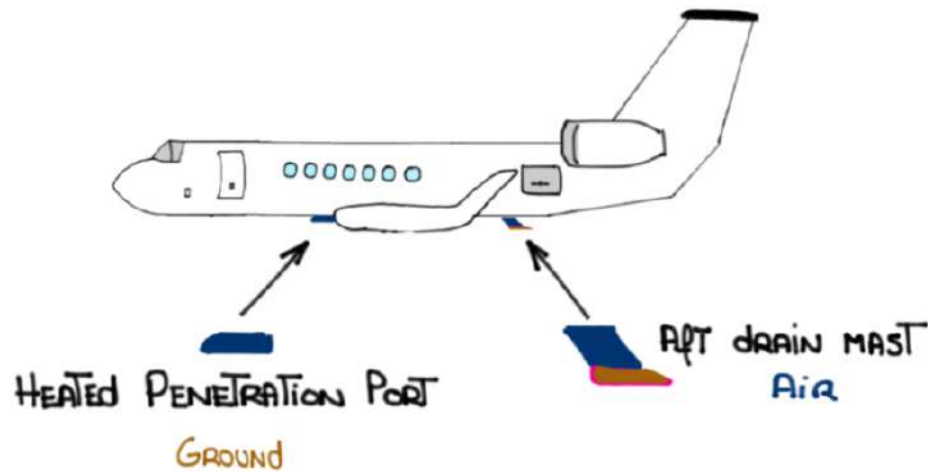

POTABLE WATER SYSTEM

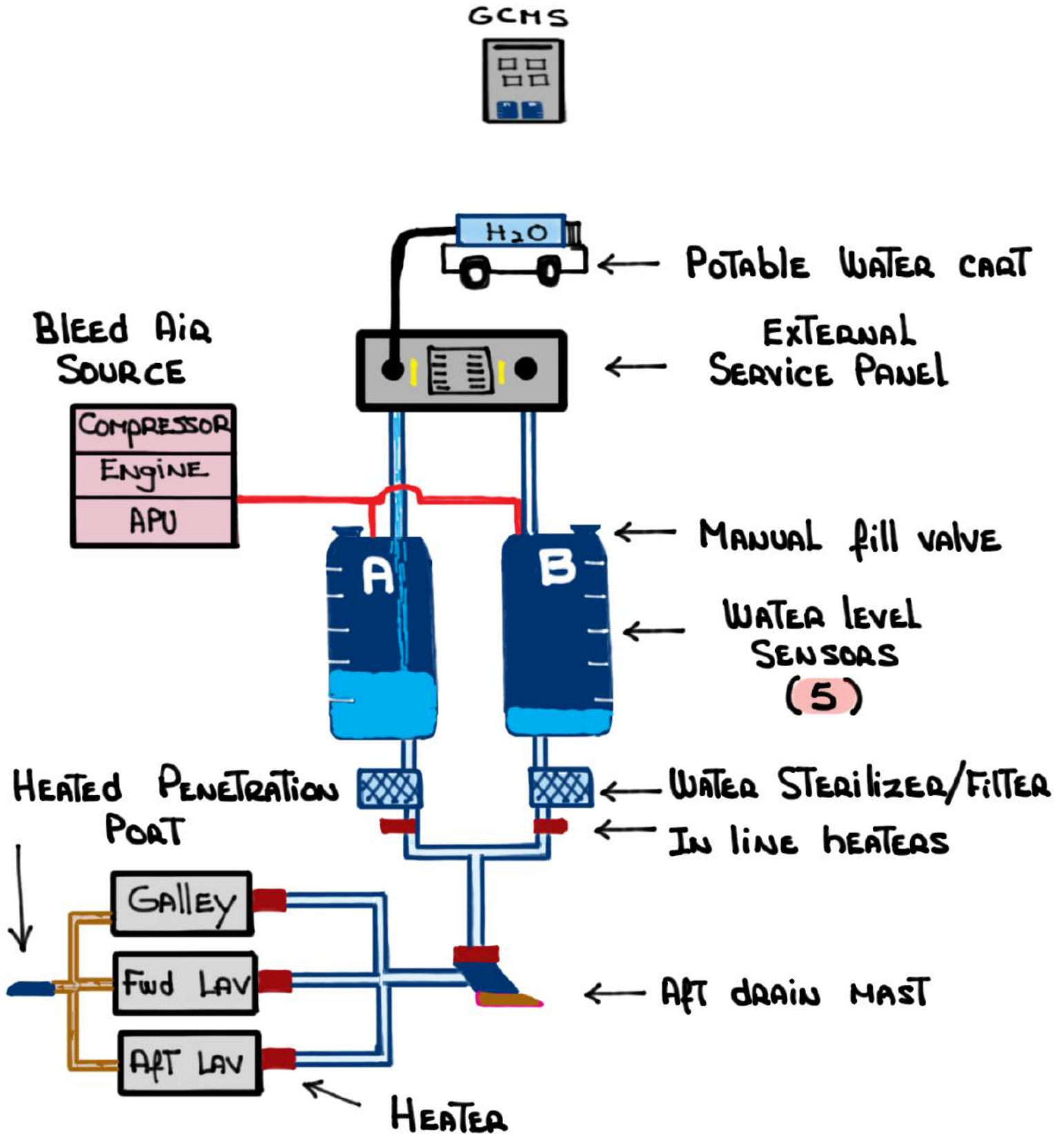

VACUUM WASTE SYSTEM

THE VACUUM WASTE SYSTEM (VWS) CONSISTS OF AN EIGHTEEN (18) GALLON STORAGE TANK WITH AN 11.5 GALLON USEABLE CAPACITY

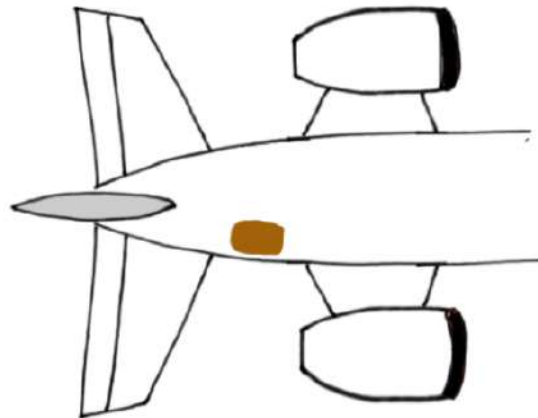
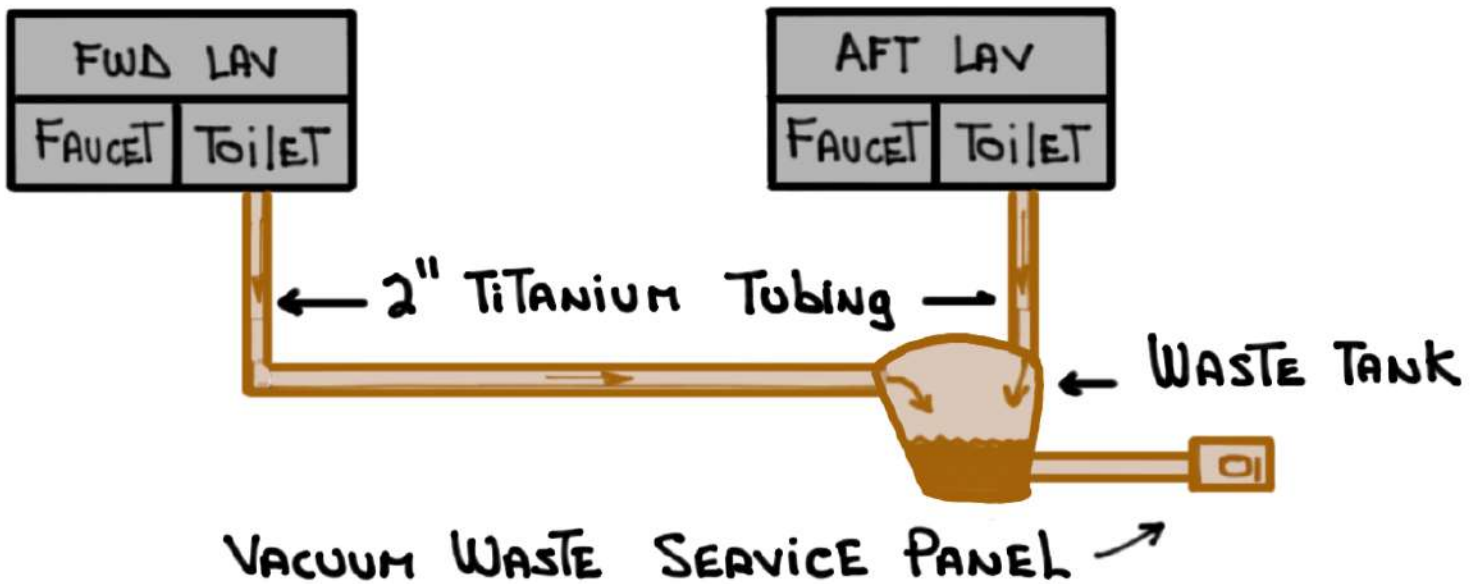

- THE WASTE TANK HAS TWO (2) SEPARATE WASTE TUBE INLETS FROM THE TWO (2) TOILETS

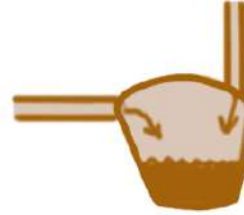

- THE VWS IS SERVICED ON THE GROUND VIA A VACUUM WASTE SERVICE PANEL LOCATED ON THE RIGHT SIDE OF THE AIRCRAFT

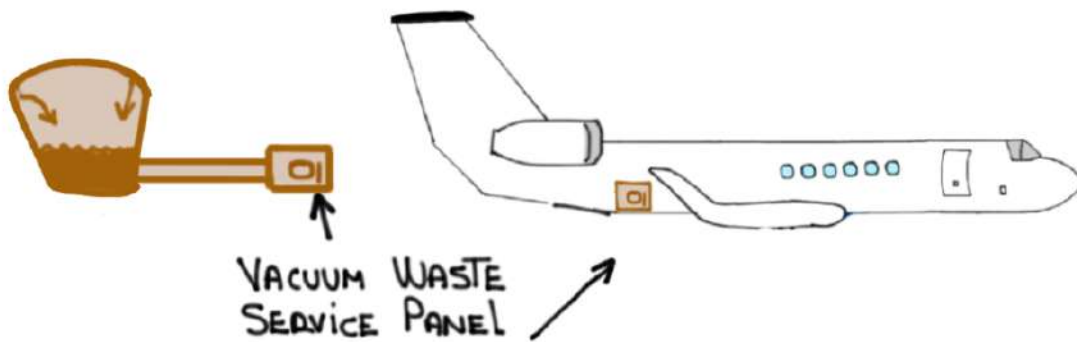

- AOM

HANDLING AND SERVICES PROCEDURES

- NO ELECTRICAL POWER REQUIRED
- THE VWS IS INHIBITED WHILE THE WASTE SERVICE PANEL DOOR IS OPEN

- The VACUUM NEED TO flush THE TOILETS is provided by EITHER ONE of TWO (2) SOURCES depending on CURRENT DIFFERENTIAL PRESSURE:

• CABIN DIFFERENTIAL PRESSURE > 6 psi

(ABOVE 16,000' FEET)

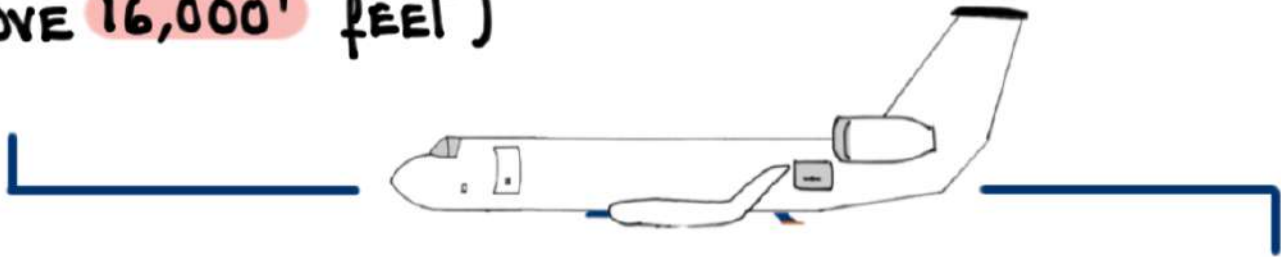

(BELOW 16,000')

• A 115
VAC POWERED VACUUM GENERATOR when
THE CABIN DIFFERENTIAL (ΔP) PRESSURE is < 6 psi

- If THE VACUUM WASTE TANK LEVEL INDICATOR ON THE GCHS INDICATES "FULL" THERE ARE STILL EIGHT (8) ELECTRIC FLUSHES LEFT



- WHEN THE VACUUM GENERATOR IS OPERATING ($\Delta P < 6$ psi) ONLY ONE (1) TOILET CAN BE FLUSHED AT A TIME

- EACH TOILET HAS A FLUSH CONTROL UNIT (FCU) WHICH PERFORMS ALL CONTROL LOGIC

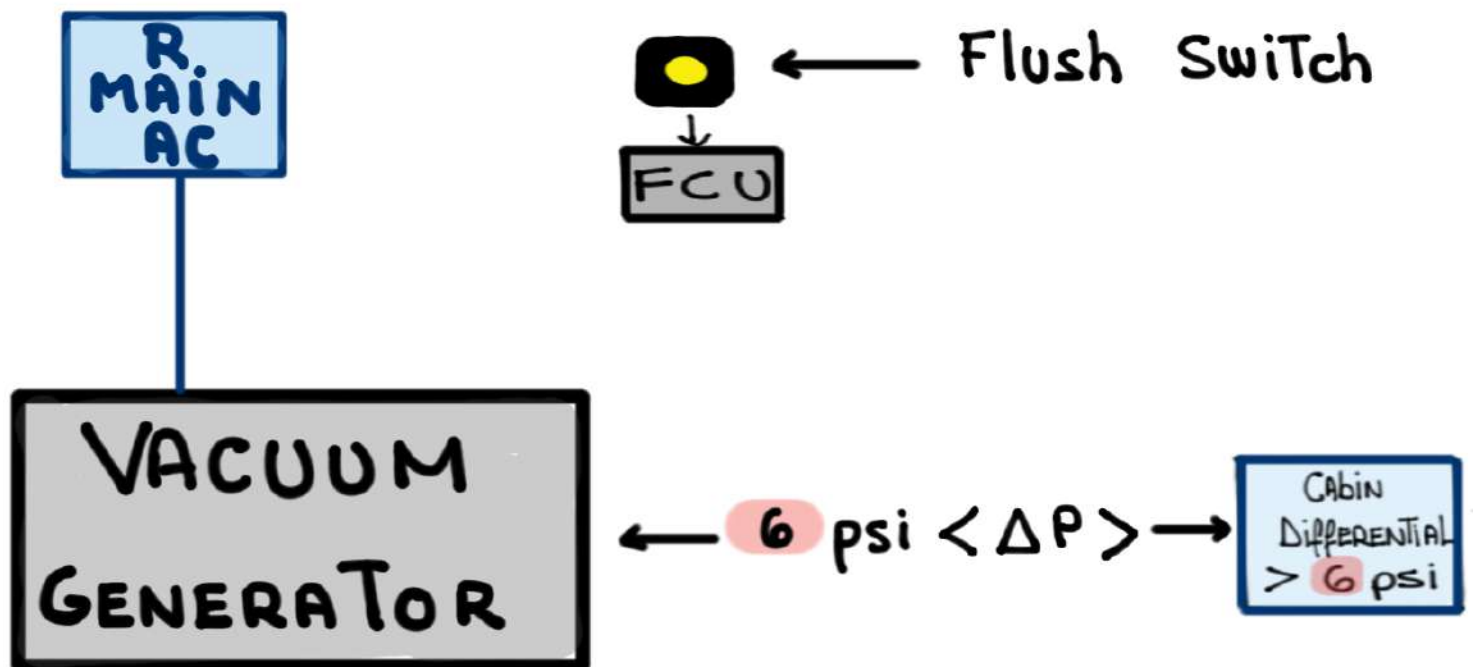

Switch PRESSED + Two (2) SECONDS

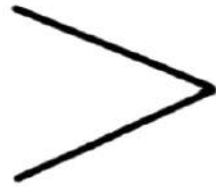
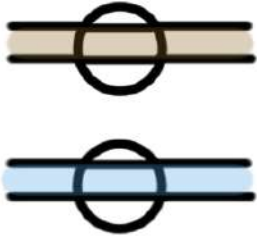

flush AND RINSE VALVES OPEN



CONTENTS ARE SUCTIONED INTO
WASTE CONTAINER

+ four (4) SECONDS

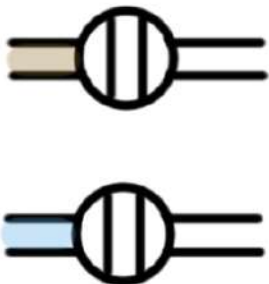

flush AND RINSE VALVES CLOSE

- FCUs ARE POWERED BY DIFFERENT POWER SOURCES

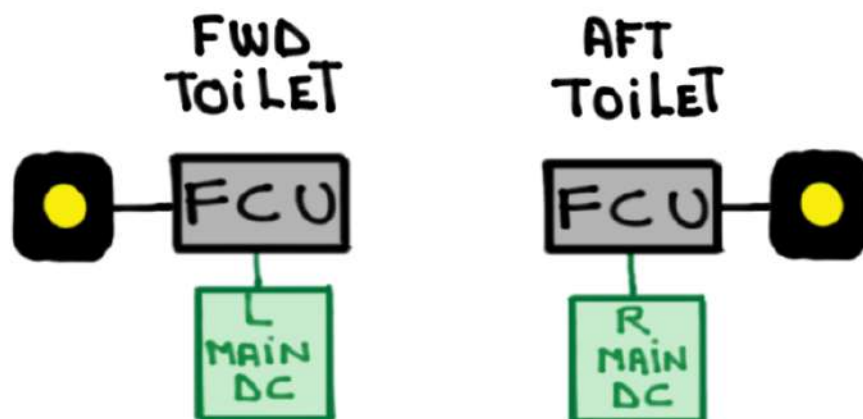
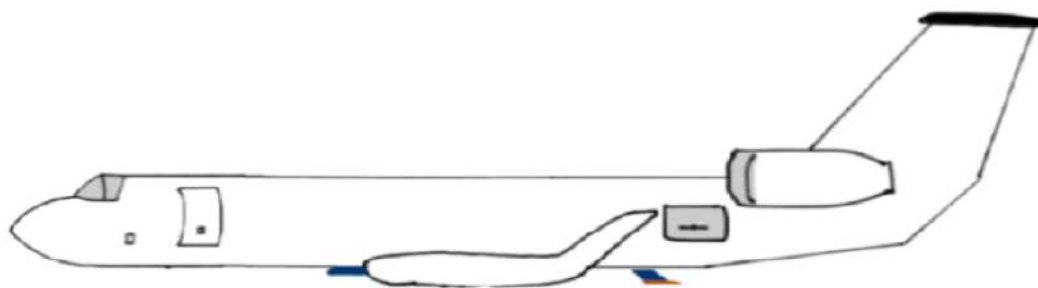

- A MANUAL flush LEVER, LOCATED UNDER THE TOILETS, CAN BE USED TO OPEN AND CLOSE THE flush VALVE WHEN THE following fails:

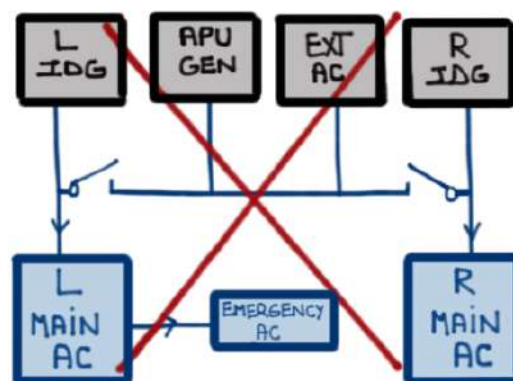

- THE MANUAL FLUSH LEVER CAN ALSO BE USED IF THE ACTUAL VALVE GETS STUCK OPEN

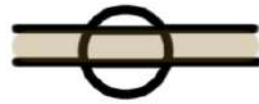

Oh yes, don't forget to lower the toilet seat... and to wash your hands!



I TRUST THESE NOTES HAVE BEEN INFORMATIVE

REMINDER: these system notes are intended for study purposes only. Always refer to official Gulfstream manuals and other approved references when operating your aircraft.

NOTE: these system notes are updated from time to time and what is posted on Code450.com will always be the most recent version.

Questions, comments or errors...please do send me an email:
ivan.luciani@gmail.com

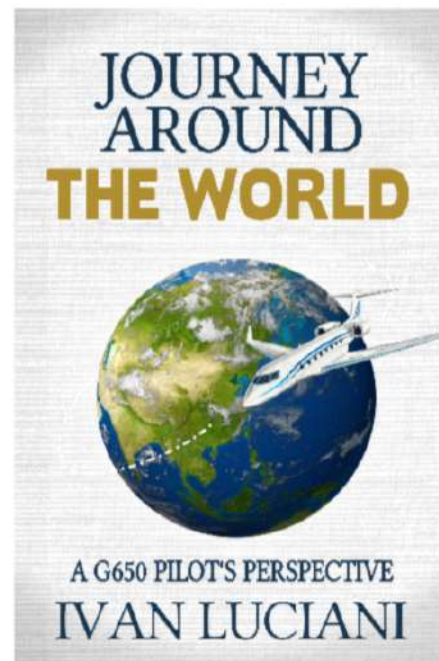
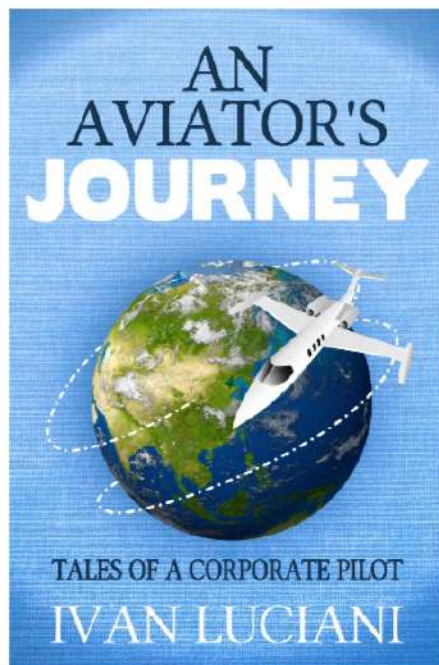

Thank you!